



SERIE

F-R

**Fustellatrice a Braccio Rotante Motorizzato
Clicking Press with Motorised Rotating Arm
Presse a Decouper avec Bras Tournant Automatisé
Cortadora a Troquel con Brazo Giratorio Motorizado**



Avvio pompa e pulsante emergenza
Pump starter and emergency button



Touch Screen



CLICKING PRESS WITH MOTORISED ROTATING ARM

The new series of F-R punching machines with motorised rotary arm is available both in EC as well as not EC versions at truly competitive prices, with the advantage of less taxing usage for operator, and consequential positive effects for company production.

The version for countries subjected to EU standards is supplied with a series of external protection devices, photo electrical protection barriers and an electrical system including various safety devices and lateral tables. For the not EC version, external protection devices with or without photo electrical barriers are supplied upon request, in this case two practical lateral tables are supplied.

Light bulb and stroke counter (additional or programmable type) are available upon request for both version.

FUSTELLATRICI A BRACCIO ROTANTE MOTORIZZATO

La nuova serie di fustellatrici F-R con braccio rotante motorizzato è disponibile sia in versione CE che Extra CE ad un prezzo sicuramente competitivo, con il vantaggio di un utilizzo meno affaticante per l'operatore, e conseguente riflesso positivo sulla produzione aziendale. La versione per paesi soggetti a normative CE è fornita di serie di protezioni esterne, barre fotoelettriche di protezione e impianto con dispositivi vari di sicurezza e tavolini laterali. Per la versione Extra CE le protezioni esterne con o senza barriere fotoelettriche sono fornibili a richiesta, in questo caso vengono anche forniti due comodi tavolini laterali.

Lampada e conta colpi (addizionatore o programmabile) sono a richiesta per entrambe le versioni.

PU VERSION



Pulsantiera di controllo Control panel with pushbuttons

TA VERSION



Tasti regolabili

Adjusting keyboard

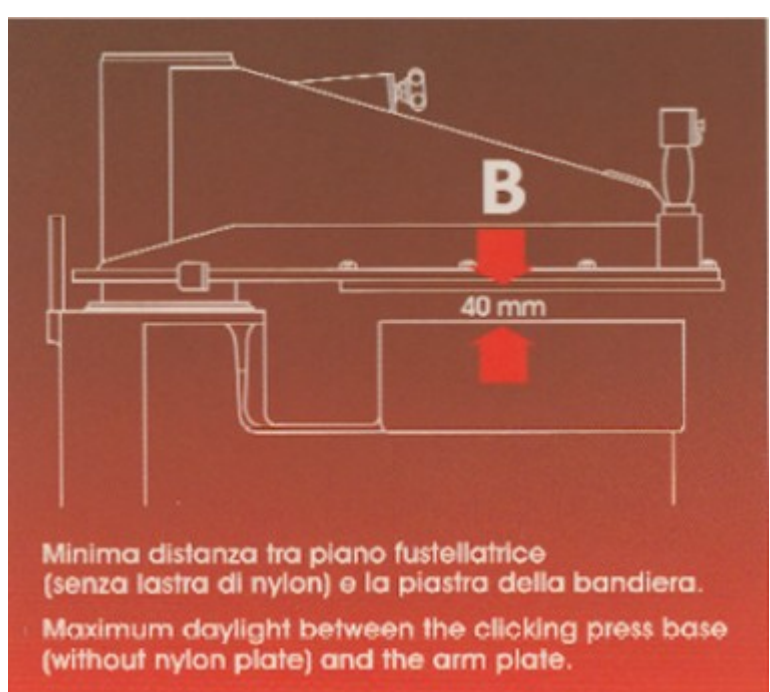
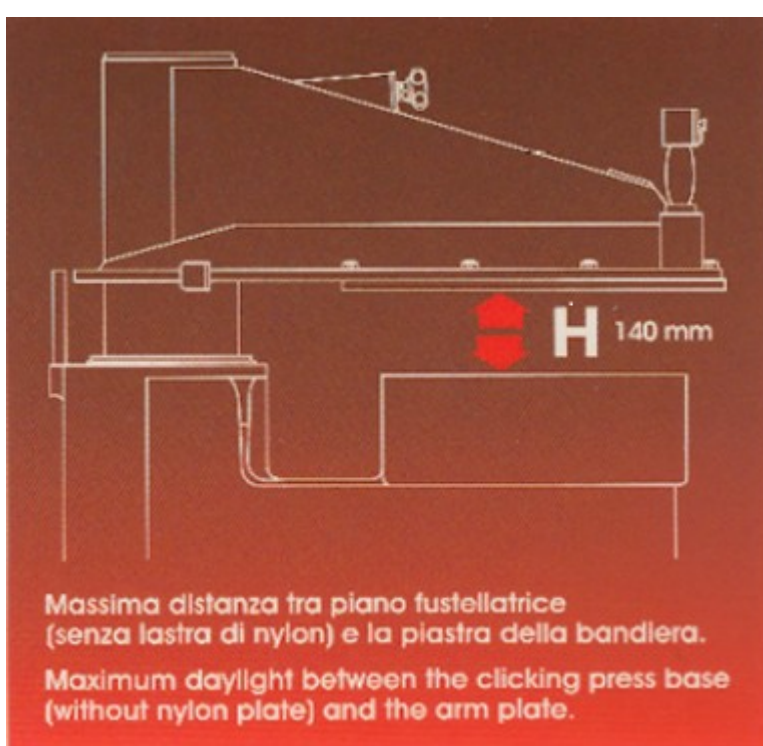

ACCESSORI

Ceppo da 50mm,
Contacolpi a 4 cifre addizionale,
Contacolpi a 6 cifre (preselezione),
Resa F.O.B.

ACCESSORIES

50mm nylon pad,
Stroke counter 4-digit (adder),
Stroke counter 6-digit (preset),
Dispatch F.O.B.

ACCESSOIRES

Souche à 50 mm en nylon
Compteur de cycles à 4 chiffres (additionneur),
Compteur de cycles à 6 chiffres (préréglée),
Envoi F.O.B.

ACCESORIOS

Bloque de nylon 50mm,
Contador de golpes de 4 dígitos (vibora),
Contador de golpes de 6 dígitos (preestablecido),
Despacho F.O.B.

| DATI TECNICI - TECHNICAL DATA - DONNES TECHNIQUES - DATOS TECNICOS | F50 R | F56 R | F60 R | F65 R | F70 R |
|--|---------------------|---------------------|---------------------|---------------------|---------------------|
| Potenza massima - Maximum power - Puissance maximale - Potencia màxima [Ton] | 27 | 27 | 27 | 27 | 27 |
| Corsa massima - Maximum stroke - Course maximale - carrera màxima [mm] | 100 | 100 | 100 | 100 | 100 |
| Piano di Lavoro - Working table - Plan de travail - Plano de trabajo [mm] | 900 x 450 | 900 x 450 | 1000 x 500 | 1000 x 500 | 1000 x 500 |
| Larghezza braccio - Arm width - Largeur du bras - Longitud brazo [mm] | 380 | 500 | 500 | 380 | 500 |
| Potenza motore pompa - Pump motor power - Puissance moteur pompe - Potencia motor bombo [Cv / kW] | 1.5 / 1.1 | 1.5 / 1.1 | 1.5 / 1.1 | 1.5 / 1.1 | 1.5 / 1.1 |
| Potenza motore rotazione bandiera - Flag rotation motor power [Cv / kW] Puissance moteur rotation porte-planche - Potenciamotor motor montado sobresaliente [Cv / kW] | 0.75 / 0.75 | 0.75 / 0.75 | 0.55 / 0.75 | 0.55 / 0.75 | 0.55 / 0.75 |
| Peso netto con olio (con lampada e protezioni) - Net weight with oil (with light and protections) [Kg] Poids net avec de l'huile (avec lampe et protections) - Peso neto con aceite (con lámpara y protecciones) [Kg] | 930 | 970 | 990 | 950 | 1050 |
| Ingombro macchina montata - Overall dimensions assembled [mm] Dimensions hors assemblés - Dimensiones máximas ensamblados [mm] | 1900x1500 H 2100 | 1900x1500 H 2100 | 1900x1500 H 2100 | 1900x1500 H 2100 | 1900x1500 H 2100 |
| Peso lordo con imballo - Gross weight with packaging [Kg] Poids brut avec emballage - Peso bruto con embalaje [Kg] | 1050 | 1090 | 1010 | 1070 | 1170 |
| Ingombro con imballo - Dimensions with packaging [mm] Dimensions avec emballage - Dimensiones con embalaje [mm] | 1050x1150 H 1570 | 1050x1150 H 1570 | 1050x1150 H 1570 | 1050x1150 H 1570 | 1050x1150 H 1570 |



ARES (Italia) S.r.l.

Corso Novara, 115 - 27029 Vigevano (PV)
Tel. +39 0381 326642 (r.a.) - Fax +39 0381 325453
info@aresitalia.info - sales@aresitalia.info - service@aresitalia.info
Web: <http://www.aresitalia.info>

